



# ATLAS SAFE

SOLUÇÕES PARA TRABALHO EM ALTURA

## FICHA TÉCNICA



LINHA DE VIDA  
KIT UP VERT  
LVV-01



PRODUTO  
NACIONAL

CÓDIGO: ATLAS LVV-01

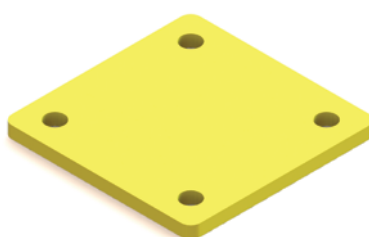

### DESCRIÇÃO

Fabricada em aço carbono certificado para resistência mecânica e pintura a pó para garantir resistência química e antioxidante. Pode ser instalada em quaisquer tipos de escadas tipo marinheiro.

Fabricado em conformidade com os parâmetros normativos da EN795, NBR16325-2C e NR35 Anexo II. Faz parte do sistema de proteção contra quedas flexível tipo C - NBR16325:2 da ATLAS SAFE.

### APLICAÇÃO

Em escadas, planos inclinados e trabalho em altura.

### ESPECIFICAÇÕES TÉCNICAS

**Fabricante:** ATLAS SAFE.

**Razão social:** ATLAS SAFE SEGURANÇA EM ALTURA LTDA.

**CNPJ:** 40.104.403/0001-03.

**SAC:** (15) 3326-3844.

**Código:** ATLAS LVV-01

### DIMENSÕES

01 Interface Superior 2000 x 120 x 46 mm / 01 Interface Inferior 500 x 105 x 46 mm / 02 Chapas Bases 100 x 100 mm



  
LEIA O  
MANUAL





# ATLAS SAFE

SOLUÇÕES PARA TRABALHO EM ALTURA

## FICHA TÉCNICA



LINHA DE VIDA  
KIT UP VERT  
LVV-01

### FIXAÇÕES

Deve ser fixada com grampos U M8 de aço INOX.

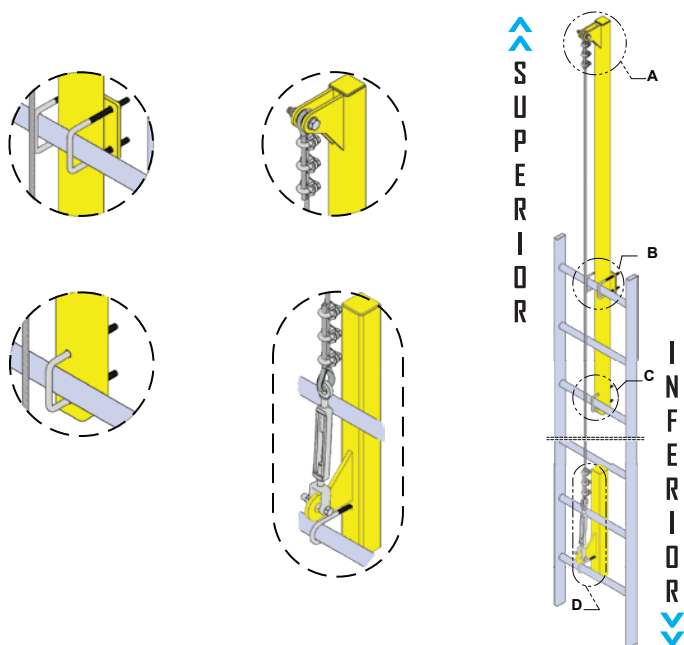

### ESTRUTURAS DE FIXAÇÃO

Pode ser fixado diretamente nas estruturas das escadas tipo marinha. **ATENÇÃO: NÃO DEVE SER FIXADO EM ESTRUTURA DE ALUMÍNIO.** Consulte a ATLAS SAFE.

**REQUISITOS PARA INSTALAÇÃO:** Deve ser instalado por PLH (Profissional Legalmente Habilitado) e dimensionado de acordo com a estrutura do local onde será instalado, analisando as resistências mecânicas e estruturais, ZLQ (Zona Livre de Quedas) e quais os componentes relacionados devem ser utilizados em conjunto com a INTERFACE PRÉ-MOLDADO LVHPM-02 para o local de instalação.



### CERTIFICAÇÕES

Projetado e Fabricado por PLH (Profissional Legalmente Habilitado), testado conforme a NBR16325 e EN795. Calculado para atender até 02 trabalhadores por linha de vida.

Documentação de Cálculo e Testes fornecida no ato da compra do produto.



### COMPONENTES RELACIONADOS



GRAMPOS U



PARAFUSOS M12



ESTICADOR  
MANILHA X DLHAL



GRAMPOS  
PESADOS



SAPATILHAS



CABO DE AÇO



# ATLAS SAFE

SOLUÇÕES PARA TRABALHO EM ALTURA

## FICHA TÉCNICA



LINHA DE VIDA  
KIT UP VERT  
LVV-01

### EXEMPLO DE PROJETO INSTALADO



### ACESSÓRIOS DE UTILIZAÇÃO



TRAVA QUEDAS  
CABO DE AÇO Ø 8mm



CINTO  
PARAQUEDISTA



CAPACETE  
CLASSE B

# CONTATO

ATENDEMOS TODO O BRASIL



(15) 3326-3844



(15) 99170-1210



vendas01@atlassafe.com.br



www.atlassafe.com.br

 Sorocaba, São Paulo

Seja um representante comercial  
**Atlas Safe** no seu estado!

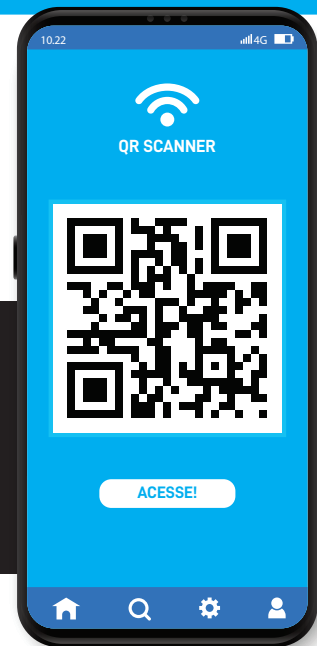

@ATLASSAFE



@ATLAS\_SAFE



ATLAS SAFE



ATLAS SAFE

www.atlassafe.com.br

